



SCORPIO™
DIRECT VENT GAS FIREPLACES



astria
FIREPLACES®

Traditional
Fireplace
Design Collection



FEATURED Scorpio shown with Old Town Red Herringbone Ceramic Fiber Liners and interior illumination

SCORPIO

The superbly designed Scorpio Series Direct Vent Gas Fireplaces are the embodiment of traditional style and performance. Dressed with an array of standard features, such as ceramic glass, factory-installed blower, full-function remote control, interior illumination and industry-leading AFUE ratings, these fireplaces are the perfect centerpiece for any room. Tradition. Style. Performance. That's the essence of the new Astria Scorpio Series Direct Vent Gas Fireplaces.



Scorpio shown with Buff Stacked Ceramic Fiber Liners and interior illumination

Options

INTERIOR (ONE REQUIRED)
Choose from four distinctive liners.

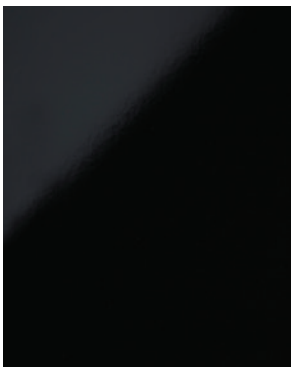

Black Reflective Porcelain Liner



Buff Stacked



Vintage Red Stacked



Old Town Red Herringbone

EXCLUSIVE FEATURES

- ◆ Available in 35", 40" and 45" clean-faced models
- ◆ Combo top/rear flue configuration for all models
- ◆ Electronic ignition with seamless battery backup to provide continued operation in the event of a power outage
- ◆ Outstanding heating efficiency for increased comfort and lower operating costs
- ◆ Smooth-faced design features ceramic glass for optimum heat transfer
- ◆ 2015 ANSI barrier compliant
- ◆ Beautifully crafted ceramic fiber "oak" log set with 1/2" diamond-shaped heavy-duty grate
- ◆ Durable textured powder coat finish
- ◆ Factory installed blower with six speed settings to fine tune your heating needs
- ◆ Interior selections (required) consist of black reflective porcelain or a variety of ceramic fiber liners
- ◆ Mood enhancing interior illumination, with six distinctive settings
- ◆ Full function remote control (thermostat, flame, blower, lighting, IPI/CPI)
- ◆ Limited Lifetime Warranty



Included ProFlame II Remote

ADDITIONAL OPTIONS



Traditional Andirons

APPLIANCE SPECIFICATIONS

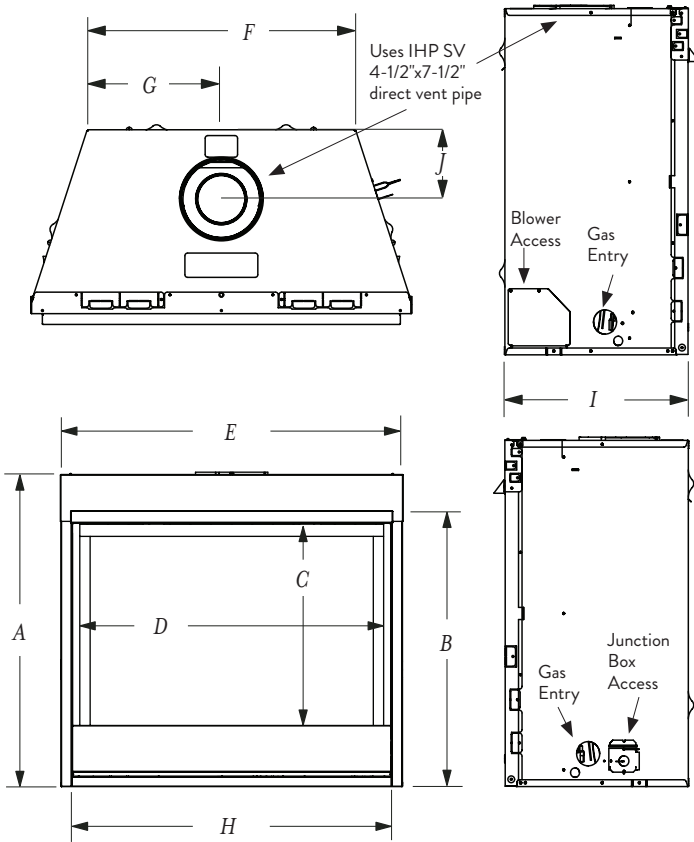

	SCORPIO 35	SCORPIO 40	SCORPIO 45
A	32-1/8"	37-1/8"	37-1/8"
B	28-3/4"	33-1/4"	33-1/4"
C	22-1/4"	27-1/4"	27-1/4"
D	32-3/8"	37-3/8"	42-3/8"
E	35-1/4"	40-1/4"	45-1/4"
F	25"	30"	35"
G	12-1/2"	15"	17-1/2"
H	32-7/8"	37-7/8"	42-7/8"
I	17"	17"	17"
J	6-7/8"	6-7/8"	6-7/8"

FRAMING SPECIFICATIONS

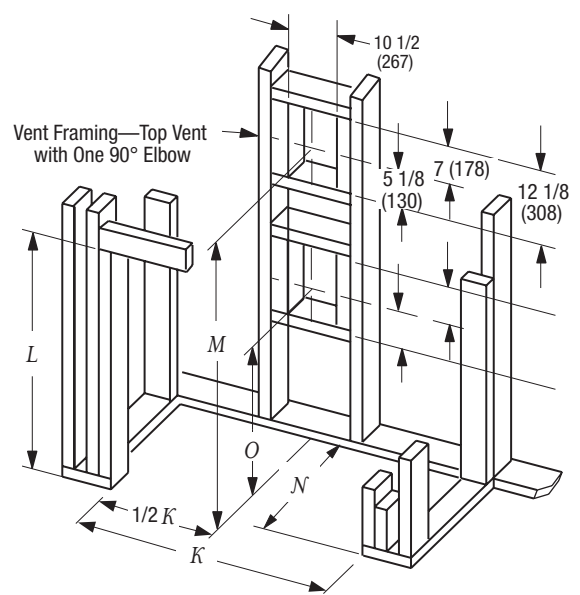

	SCORPIO 35	SCORPIO 40	SCORPIO 45
K	35-3/8"	40-3/8"	45-3/8"
L	36-1/4"*	41-1/4"*	41-1/4"*
M	38-3/4"	43-3/4"	43-3/4"
N	18"	18"	18"
O	23-3/8"	28-1/4"	28-1/4"

* Includes 4" for fold-up standoffs

FIREPLACE EFFICIENCIES

MODEL	FUEL	BTU/HR	AFUE**	P4 / ENERGIDE*
SCORPIO 35	NG	20,000	70%	64.0%
SCORPIO 35	LP	19,000	70%	64.0%
SCORPIO 40	NG	24,000	70%	64.0%
SCORPIO 40	LP	22,000	70%	64.0%
SCORPIO 45	NG	28,000	71%	65.0%
SCORPIO 45	LP	26,000	71%	65.0%

*Intermittent ignition systems.

**Annual Fuel Utilization Efficiency (AFUE) is the recognized U.S. rating system for the total efficiency of heating products.

On the cover: Scorpio shown with Old Town Red Herringbone Ceramic Fiber Liners and interior illumination

IMPORTANT NOTES:

As with any fireplace, this appliance is extremely hot during operation. Read and understand all operating instructions before using this appliance. For further information, consult your dealer.

Local conditions, such as elevation, wind, vent configuration and choice of fuel will affect overall appearance of the fire and heating performance. Performance can also vary with home design and insulation, climate, condition and type of fuel used, appliance location, burn rate, accessories chosen, chimney installation and how the appliance is operated.

Diagrams, illustrations and photographs are not to scale—consult installation instructions. Product designs, materials, dimensions, specifications, colors and prices are subject to change or discontinuance without notice.



Approved for use with European Copper and Chimney Classics chimney tops, which improve performance and add an elegant touch.

astria
FIREPLACES®

© 2015 Innovative Hearth Products

785575M 07/15

Visit us online



Astria.us.com

PFS
C US
Report #F13-094

